

E55 Type Relations

Philipp Gerth, Wolfgang Schmidle

For the different forms of E55 Type relations we have two different scenarios to explain our thoughts and suggestions on it. For the exemplified mappings we have used a simplified version of CIDOC CRM in order to make the diagrams more easily readable.

Fibula Chronology

There are different so-called small finds chronologies in archaeology, which help archaeologists identify the dating of an archaeological context. They evolved over time through analysis of large collections of data with the help of multivariate statistic, e.g. correspondence analysis. One very important chronological system for the bronze and iron age is the fibula chronology, which is based on fibulae:

[https://en.wikipedia.org/wiki/Fibula_\(brooch\)](https://en.wikipedia.org/wiki/Fibula_(brooch))

Leitformen	Dendrodaten
<p>Ha D3</p> 	<p>520 ±10 Heuneburgtor, Periode 1a</p>
<p>Ha D2</p> 	<p>573 Rennertshofen, Feldmühle</p>
<p>Ha D1</p> 	<p>593 Magdalensberg, Nachbestattung</p> <p>616 Magdalensberg, Nachbestattung</p> <p>641 ±10 Niedererlbach, Hügel 3</p> <p>692 Magdalensberg, Erstbestattung</p>
<p>Ha C</p> 	<p>667 ±10 Dautmergen</p> <p>778 ±5 Wehringen, Hügel 8</p>

Figure 1 "Leitformen" of the Hallstatt age

In the following, we took the “Paukenfibel” as an example within the chronological system. It is a so-called “Leitform” for Hallstatt D2 and Hallstatt D3. A “Leitform” is a characteristic object for a specific period. The term derives from the geological term “Leitfossil” (eng. Index fossil). However, the Paukenfibel is also used until the end of Latane A. This is expressed in the following diagram (Figure 2), using different terms. The diagram itself shows the embedding in the chronological system of the Hallstatt Period.

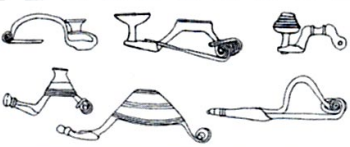
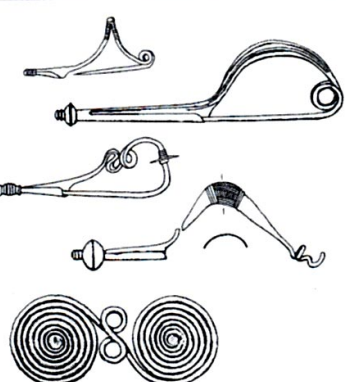
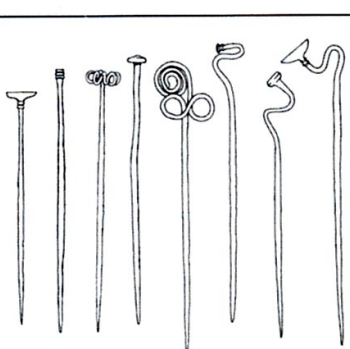
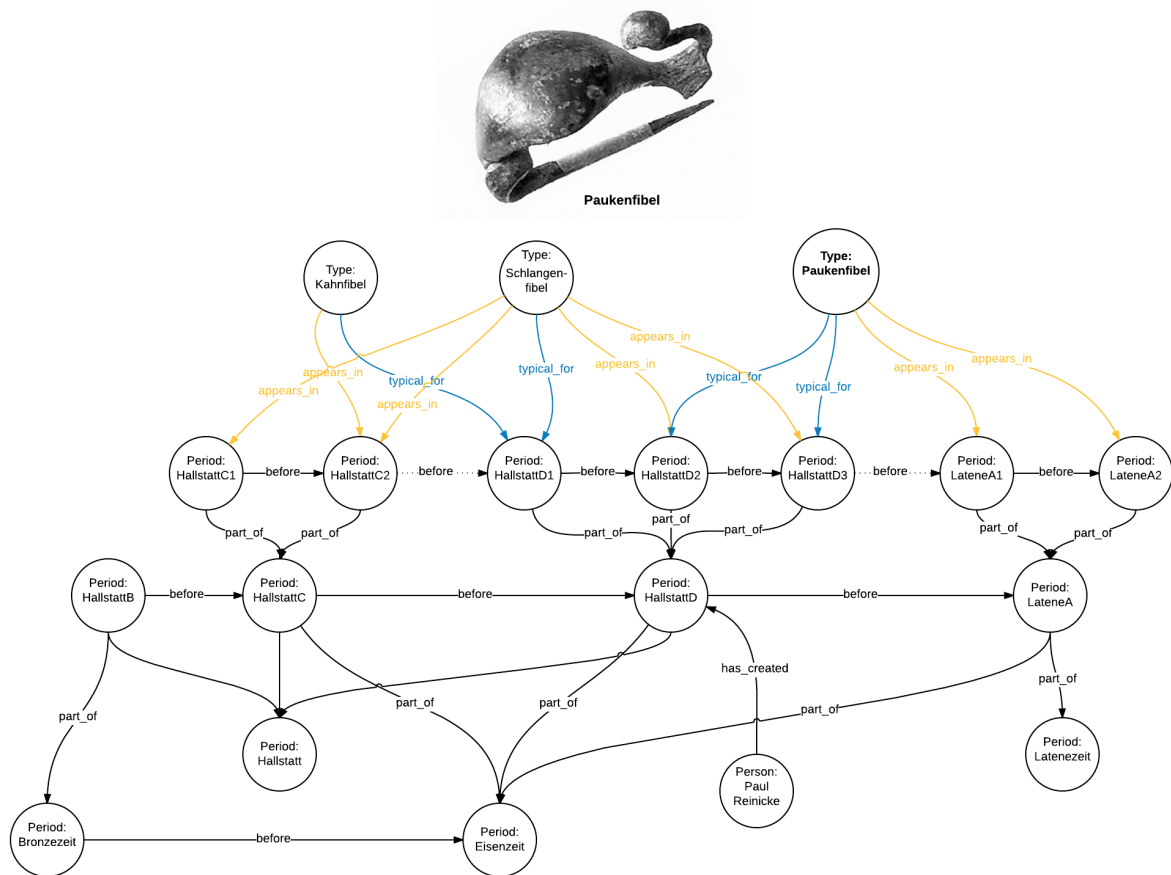

Figure 2 Exemplified mapping of periods and fibulae

For the three fibula types the different times in which they occur can be expressed by using “appears in”, while the characteristic usage as a “Leitfossil” for a specific period can be expressed via “typical for”. “appears in” is referring to the time, when the object was produced.

There might also be the need to express a specific time period in which and only in which objects of a given type have been created. This is comparable to the “Closed world assumption” where the absence of an “appears in” statement for a specific period implies the fact that no exemplars of this type have been manufactured in this period. This could be expressed via “restricted to”, but we suggest that this restriction as a TimeSpan could be aggregated by the sum of all “typical for” and “appears in” assigned periods. The semantics of “restricted to” should be handled as bounding box, so that there are no other finds outside the temporal bounding box, as long as they are not found. “restricted to” means implicit that some finds occur during the

So for the “Paukenfibel”, the restricted timespan could be all Periods starting from Hallstatt D2 and ending in Latene A2. In that case the restriction isn’t modelled explicitly but the information, but could be derived from the implicit knowledge. We suggest a sum of all periods, which are related via “appears to” or “typical for” to the specific object as shown in figure 3.

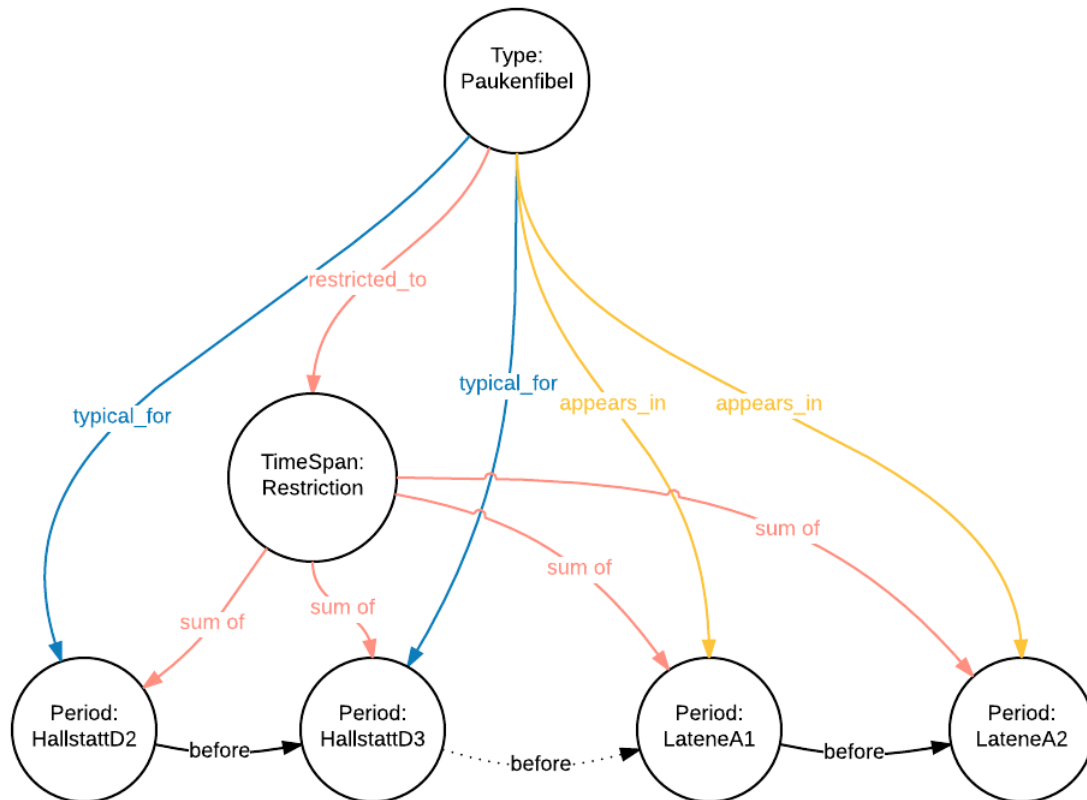

Figure 3 Creation of a temporal restriction for the Paukenfibel out of implicit knowledge

Sculpture Types

The second example is taken from classical archaeology. Sculptures can also be classified into different types. Some of the types are based on one specific object, which is the characteristic master object for all following objects of the same kind. This master object then lends its name to the whole type. One example for this is the Type “Augustus Prima Porta” (<http://arachne.dainst.org/entity/1242112>), which is named after one specific statue, the “Panzerstatue des Augustus von Prima Porta” (<http://arachne.dainst.org/entity/1079332>). One criteria for the type itself is defined by the way the hairstyle is modelled on the statue. The “Panzerstatue des Augustus von Prima Porta” shows the Roman emperor Augustus and therefore the whole type is typical for the Augustan Age as defined as the reign of the emperor (31 BC - 14 AD). However, the type was still in use long after the emperor died, i.e. until the Claudian Age (41 - 54 AD).

In the diagram (Figure 4), we modelled this appearance as a timespan, starting from the Augustan Age until the Claudian Age. It may be partially redundant, as the Augustan Age is already modelled as “typical for”, which is a stronger relation than (and in fact implies) “appears in”. But it is easier for longer continued timespans than individually describing the reign of every emperor where the statue type was in use.

The figure also briefly shows three more topics connected to this type:

1. **Reproduction:** This type of statue was reproduced in the Renaissance as a new type, which is influenced by the ancient type.
2. **Type → Literature & Type Creation / Assignment:** One case is modelled for the new assignment and creation of a type by German Hafner and the modification, refining or other view of that type by other scientists, like Paul Zanker in the example. It is in our opinion important to model the creator of a new type and the scientists who refined/discussed the type separately.
3. **Type → Location / STV:** The STV and the Chorology of a type is hard to express explicitly, but could also be derived by creating the sum of the STVs / Locations of all objects of this specific type.

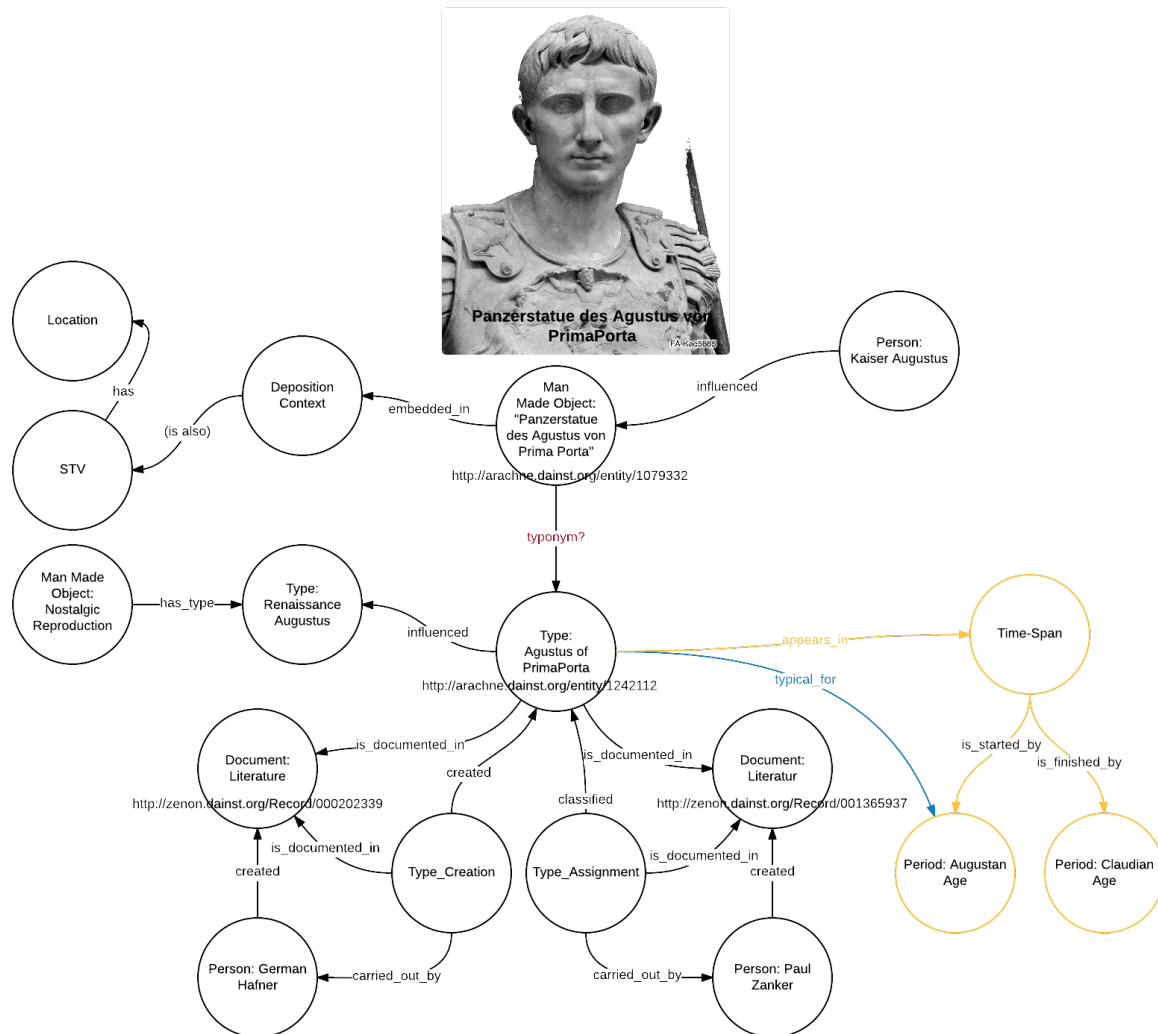

Figure 4 Exemplified mapping of the sculpture Type "Augustus von Prima Porta"

Open Points

- Is it more precise to model the sum of periods as a timespan or a period itself?
- How should a hiatus be expressed then? So the stopped and later on picked up usage of the same object. As a second timespan / period attached to the appearance of an object?
- Relation of Types and objects that refer to that type: Is it important to have at least one object for a "appears in" assignment to refer to?